

GL-235

Solar Pool Controller



Installation & Operation Manual

Description

The GL-235 is a differential temperature control for solar heating of pools, spas, and hot tubs. It provides differential temperature control with an adjustable, calibrated water temperature high limit. Automatic nocturnal cooling (for pools that overheat in hot climates) and recirculate freeze protection functions can be enabled/disabled via internal jumpers.

Input power can be either 115 or 240 VAC. The output controls a 24VAC automatic valve actuator. For older systems with 12VAC valves, an internal jumper can be moved to select 12VAC output operation. The GL-235 also has a high voltage output for controlling a filter pump or booster pump.

Specifications

Power:	105-130VAC, .5A 50/60Hz. or 195-250VAC, .3A 50/60Hz	Desired Pool Temp.:	70-104°F calibrated scale or Solar Off, 75 (24°C) -104°F (40°C) on some models
Output:	Selectable low voltage 24VAC, 20VA, .85A or 12VAC, 20VA, 1.7A SPST-NO isolated contact 115VAC 1HP 240VAC 2HP	Recirculate freeze:	On at ≤40°F (4.5°C), off at ≥42°F (5.5°C), Enabled via jumper
Sensors:	2 required (thermistor, 10Kohm @ 25C/77°F).	Nocturnal cooling:	On when collector 8°F less than pool and pool hotter than limit, off when collector 3°F less than pool or pool cooler than high limit. Enabled via jumper
Differential:	on at 4°F, off at 1.5°F		

Installation

Mounting

The GL-235 is designed for outdoor use. Mount the box vertically with the knockouts facing downward. For safety, the GL-235 must be a minimum of 5 feet (horizontally) from the pool or spa.

Power input

Turn off power at circuit breaker before wiring. Remove the internal panel to expose the wiring connections. Either 115VAC or 240VAC can be used. Refer to the input wiring diagram (Figure 1) on next page. **WARNING: Applying 240VAC to the 120VAC input terminals will cause permanent damage to the control.**

Grounding

Refer to NEC and local codes for specific grounding requirements. In general, a separate ground conductor must be run to the ground terminal on the pool service panel.

Low Voltage (LV) output: Solar Valve

The GL-235 controls a single valve. In most applications this is the solar valve, which diverts water through the collector panels or through the normal pool loop depending on conditions.

All controls are shipped with the output voltage set to the industry standard 24VAC. To use the GL-235 with older 12VAC valves, move jumper J4, located on the right side of the circuit board.

The GL-235 provides two different types of connections to the pool/spa actuators. For older actuators with no wire end connector, a 3 position terminal block is used. Connect the wires to the proper terminal block according to the color code shown in Figure 4. If the valve operates opposite to the way it is supposed to, reverse the red and white wires. Be careful not to short the valve output wiring. The GL-235 is fused and shorting the output will require replacing the fuse.

For newer Goldline, Compool, Hayward, and Jandy actuators (with wire end connectors), two 3-pin connectors are supplied. Plug the actuator into one of the two 3 pin connectors as shown in figures 2 or 3. If the valve operates opposite to the way it is supposed to, disconnect and plug into the other connector.

High Voltage (HV) output: Booster Pump

The GL-235 can control a high voltage booster pump in addition to the normal low voltage solar valve. Note the high voltage relay contacts are isolated so that the booster pump can be run on a separate circuit, as required by many local codes. The GL-235 turns on, the valve output will operate first, and then the HV relay will operate 30 seconds later.

High Voltage (HV) output: Timeclock Override

The GL-235 can also be used to override the filter pump timer. This is very important if recirculate freeze protection or nocturnal cooling functions are being used. Also, this function can be used on systems where the system should operate whenever solar heat is available, regardless of the timer settings. The HV relay will operate approximately 30 seconds after the LV relay.

Sensor Mounting and Wiring

Most installations use a PC sensor to measure the pool temperature and another PC sensor to measure the solar temperature. Alternatively, an SC-1/4 sensor can be screwed into the pump strainer basket to measure the pool temperature.

Pool Sensor: Drill a 3/8" (or 5/16") hole in the PVC pipe. Remove burrs around the hole. Check that the O-ring is seated on the PC sensor and then insert sensor into pipe. Tighten hose clamp over the sensor to make a seal—DO NOT OVERTIGHTEN.

Solar Sensor: Use a screw or silicon adhesive to attach the sensor near the solar collector array. The sensor does not have to be attached to the collectors. It is only important that the sensor be exposed to the same sunlight as the collectors. Additionally, the underside of the sensing element may be covered with silicon to minimize wind cooling.

Other 10K ohm Goldline sensors may be substituted. Wire should be twisted pair 20AWG. Sensor wiring run outdoors must be rated for outdoor use and ensure that the wire connections are protected from the weather. **Do NOT run sensor wires in the same conduit or multiconductor cable as the valve actuator wires or any 120/240V circuit.** For long runs or runs near other electrical wiring use shielded cable (Belden 8428 for outdoor use). Ground the shields to the GL-35/LV ground screw.

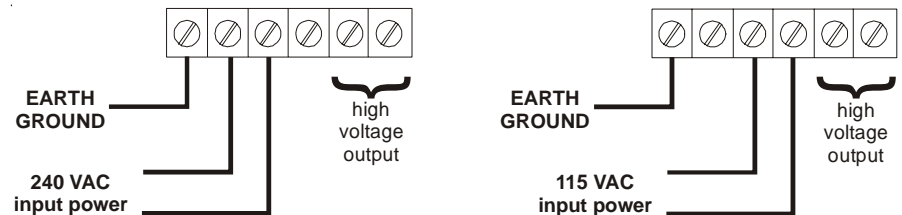

Figure 1

Freeze Protection

If you are relying on the collectors naturally draining to provide freeze protection, it is very important that you use a **non-positive seal valve or drill a hole (1/8"--1/4") in the diverter of a positive seal valve to allow the collectors to drain.** Alternatively, the GL-235 control can provide recirculate freeze protection. If enabled, when the GL-235 senses a freeze condition at the collector sensor, it will allow circulation of relatively warm water from the pool to the collector panels.

The GL-235 will allow recirculation when the collector temperature falls below 40°F and will stop circulation when the collector temperature rises above 42°F. While this type of freeze protection has proven to be adequate in relatively mild climates, it is extremely important that the sensors be properly placed and that the homeowner realize that the system is unprotected in the event of a power failure. Recirculate freeze protection is NOT recommended in climates where freezing temperatures are common or last for extended periods.

Goldline strongly recommends the use of GC-3 freeze snap switches if freeze protection is being utilized. Snap switches should be wired in series with the collector sensor. Placement of the snap switches at the coldest point of the collector array and exposed plumbing will help assure that freeze protection starts early enough to protect the system.

The GL-235 is shipped from the factory with recirculate freeze protection disabled (the jumper is present but installed on one pin only). To activate recirculate freeze protection, install the jumper across both pins marked "RECIRC", located near the top right of the main circuit board.

If recirculate freeze protection is to be used on a GL-235, either:

- The filter pump must be set for continuous operation *or*
- The GL235 High Voltage Output must be wired for Timer Override function.

Nocturnal Cooling

The GL-235 has nocturnal cooling logic, which can be enabled/disabled via a jumper on the main circuit board. During nighttime hours, when enabled, the GL-235 will circulate relatively warmer water from the pool to the collector panels, thus cooling the pool over time. The GL-235 will circulate water when the collector temperature AND the pool temperature is hotter than the high limit setting. Circulation will stop when the collector temperature is 3°F less than the pool temperature OR the pool temperature is cooler than the high limit setting. The GL-235 is shipped from the factory with nocturnal cooling disabled (the jumper is present but installed on one pin only). To activate nocturnal cooling, install the jumper provided onto the two pins marked "COOLING" located near the top right of the main circuit board.

If nocturnal cooling is to be used, either:

- The filter pump must be set for continuous operation *or*
- The GL-235 High Voltage Output must be wired for Timer Override function.

Operation

For normal operation place the switch in the “AUTO” position and adjust the desired pool/spa temperature setting. The “Power” LED indicator should always be on. (NOTE: During initial power up, the “POWER” indicator will blink for approximately 10 seconds while it stabilizes temperature readings). The “Heating” LED indicator will show when the system is collecting solar heat. If the nocturnal cooling function is enabled inside the GL-235, the “Cooling” LED indicator will show when the system is dissipating excess heat.

In the “AUTO” position, the GL-235 will heat the pool or spa (rotate valve to solar loop) when the collector (solar) sensor temperature is higher than the pool/spa sensor temperature by 4°F or more AND the pool/spa temperature is less than the "Desired Temperature" setting. The GL-235 will stop heating (return valve to pool loop) when the two sensor temperatures get to within 1.5°F OR the pool/spa sensor is above the "Desired Temperature" setting.

To test the system, move the switch to “MANUAL TEST” and verify that both the “Heating” and “Cooling” indicators light and that the valve(s) are in the solar loop position. Move the switch to “MANUAL OFF” and verify that all indicators except “Power” are off. The valve(s) should be in the normal recirculating loop position. If the valve(s) positions are working in reverse, follow the instructions in section marked “**Low Voltage (LV) : Solar Valve**” to correct. **WARNING: If recirculate freeze protection is being used, do NOT leave the switch in the “MANUAL OFF” position during cold weather.** Also note that the switch does NOT turn power off to the GL-235.

Troubleshooting

No Power Indicator

- Check main power circuit breakers.
- Check fuse

Fuse Replacement

The GL-235 is protected by a fuse located on the left side of the main circuit board. Replace the fuse with a 2A, type ATO-2 fuse, readily available in most automotive or electronics stores.

If “Heating” is always on

Disable recirculate freeze protection if enabled. Check that the switch is in the “AUTO” position. Next verify that the control circuitry is operating properly by disconnecting the solar sensor from the terminal block. The “Heating” LED should go off and the “CHECK SENSOR” LED should begin to blink. If “Heating” remains on, there is an internal circuit failure and the GL-235 will have to be returned for repair.

If “Heating” never comes on

Verify that the switch is in the “AUTO” position, the desired pool temperature dial is set higher (hotter) than the actual pool temperature, and the solar sensor is warmer than the pool water. Also check that the switch on the valve actuator is NOT in the "OFF" position. Disconnect the pool sensor from the terminal block and verify that the “CHECK SENSOR” LED turns on. If the “CHECK SENSOR” LED does not turn on, there is an internal failure and the GL-235 will have to be returned for repair. Reconnect the pool sensor and verify that the “Check Sensor” LED turns off. Next, disconnect the “solar” sensor from the terminal block and verify that the “CHECK SENSOR” LED begins to blink. If the “CHECK SENSOR” LED does not begin to blink, there is an internal failure and the GL-235 will have to be returned for repair.

“CHECK SENSOR” indicator on

If the “CHECK SENSOR indicator is on and NOT blinking, there may be a possible open circuit or short circuit with the pool sensor. Using a voltmeter, measure the DC voltage across the terminals of the pool sensor as indicated in figure 5. If the voltage is close to zero volts, the sensor has a short to ground. Remove the sensor from the terminal block and measure the voltage across the pool terminals again. If the voltage is still close to zero volts, there is an internal short and the unit must be returned for repair. If the voltage is close to five volts, the pool sensor itself may be at fault.

With the sensor disconnected from the unit, measure the resistance of the sensor using an ohmmeter. At room temperature (25°C/77°F) the sensor should measure approximately 10K ohms (10,000 ohms ± 1%). For other resistance measurements at different temperatures, consult the table at back of manual. If the sensor is not returning the correct value, it is defective and will need to be replaced. If the sensor is returning approximately the correct value, reconnect it to the terminals marked “POOL SENSOR”. If the “CHECK SENSOR” indicator remains on, the unit is defective and needs to be replaced.

“CHECK SENSOR” indicator blinking

If the “CHECK SENSOR indicator is blinking, there may be a possible open circuit or short circuit with the solar sensor. Using a voltmeter, measure the voltage across the terminals of the solar sensor. If the voltage is close to zero volts, the sensor has a short to ground. Remove the sensor from the terminal block and measure the voltage across the solar terminals again. If the voltage is still close to zero volts, there is an internal short and the unit must be returned for repair. If the voltage is close to five volts, the solar sensor itself may be at fault.

With the sensor disconnected from the unit, measure the resistance of the sensor using an ohmmeter. At room temperature (25°C/77°F) the sensor should measure approximately 10K ohms (10,000 ohms ± 1%). For other resistance measurements at different temperatures, consult the table at back of manual. If the sensor is not returning the correct value, it is defective and will need to be replaced. If the sensor is returning approximately the correct value, reconnect it to the terminals marked “SOLAR SENSOR”. If the “CHECK SENSOR” indicator remains on, the unit is defective and needs to be replaced.

If FREEZE PROTECTION is enabled:

When a sensor is disconnected from the unit and freeze protection has been enabled, the SENSOR FAULT light will NOT activate. The GL-235 will recognize this as a freeze condition and activate freeze protection.

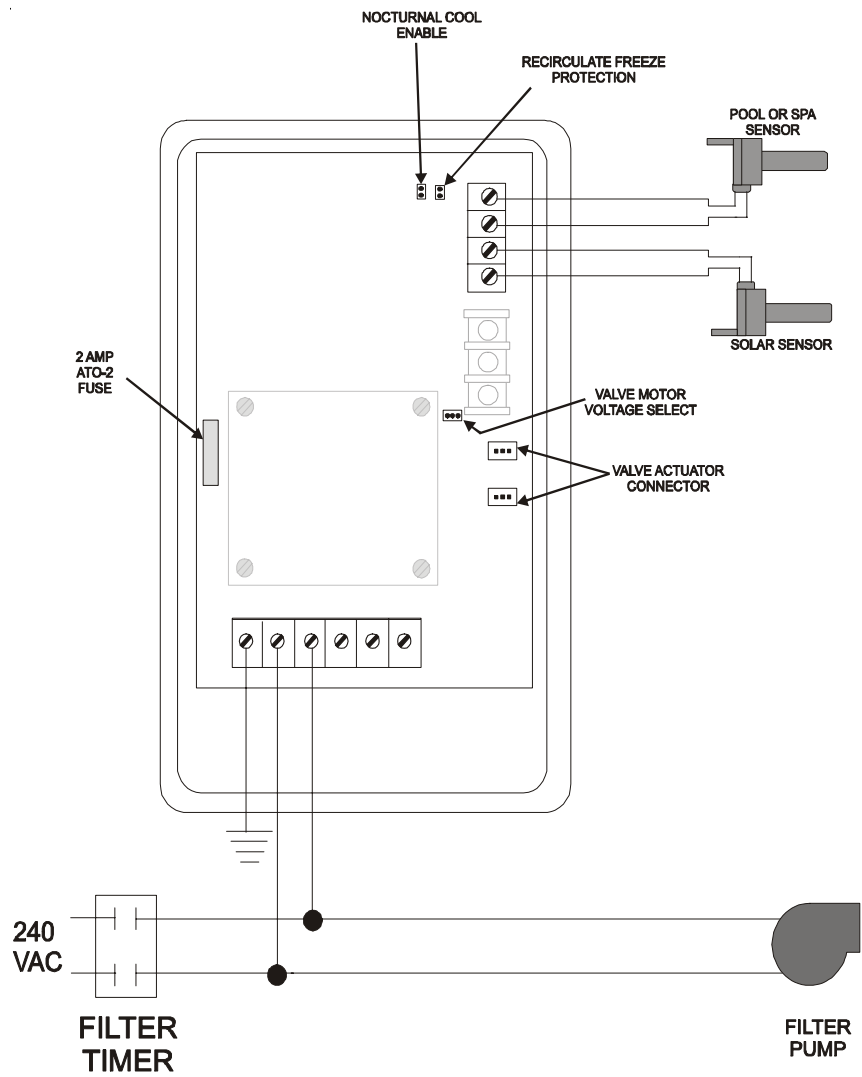

Basic Installation of GL-235

Figure 2

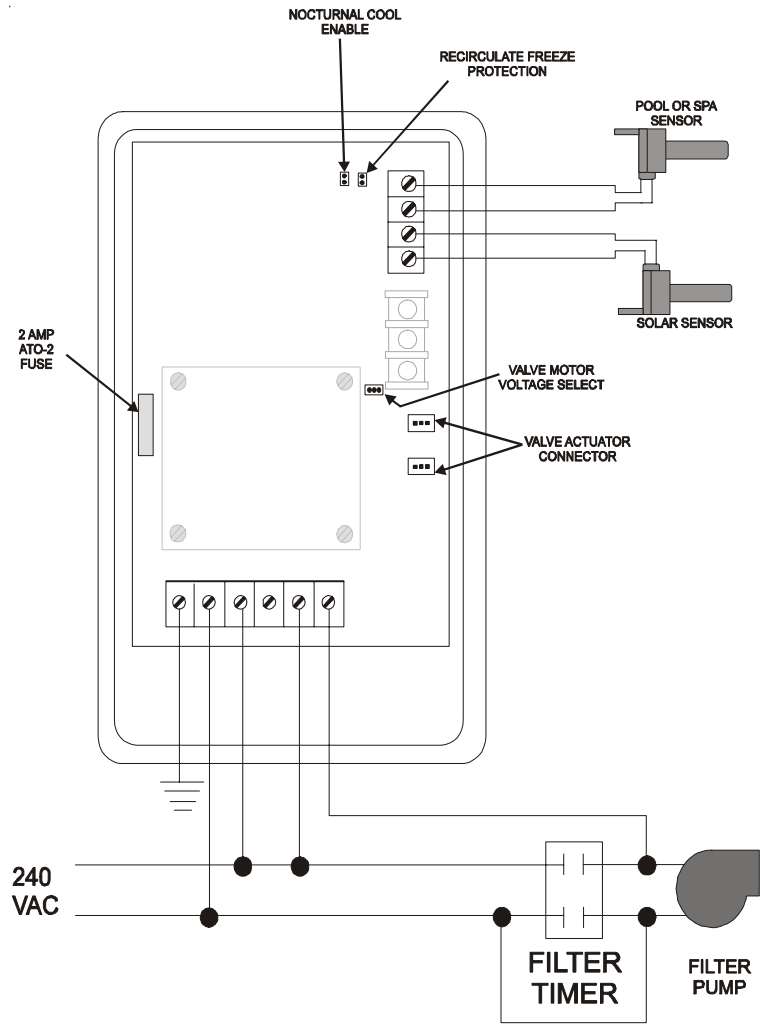

GL-235 high voltage output used for Timer Override

Figure 3

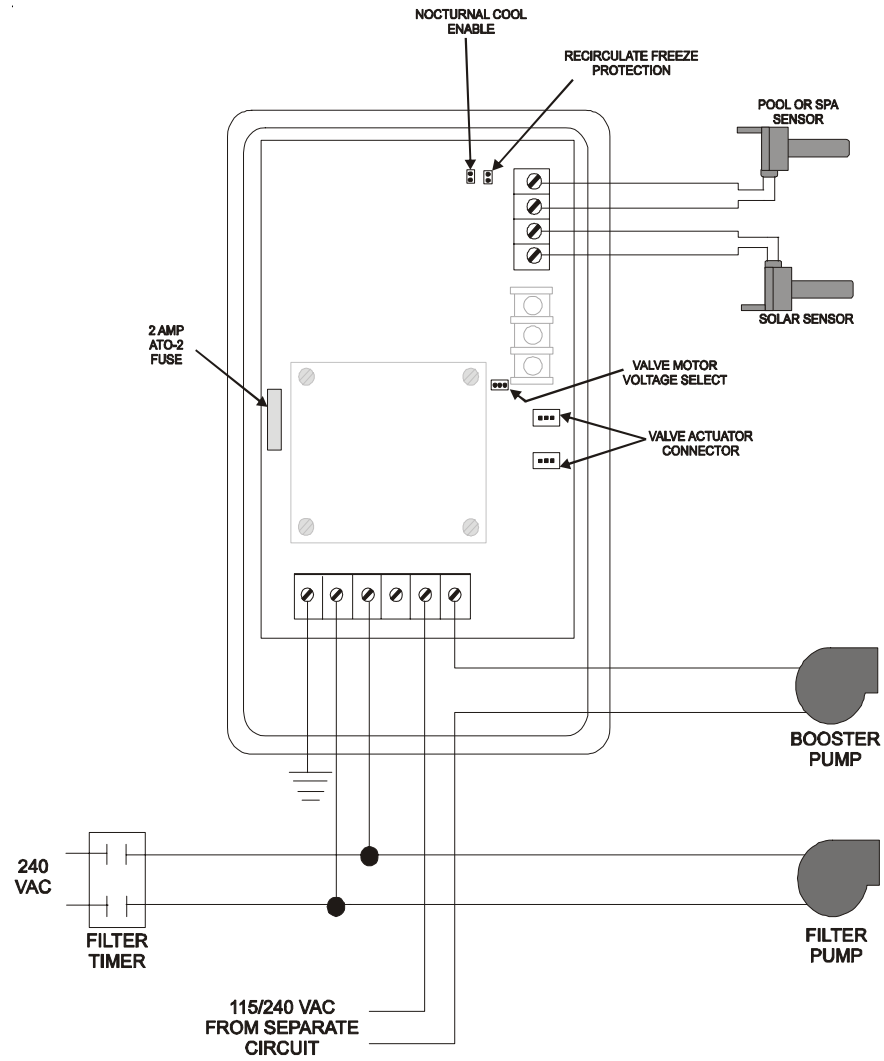

GL-235 high voltage output used for Booster Pump

Figure 4

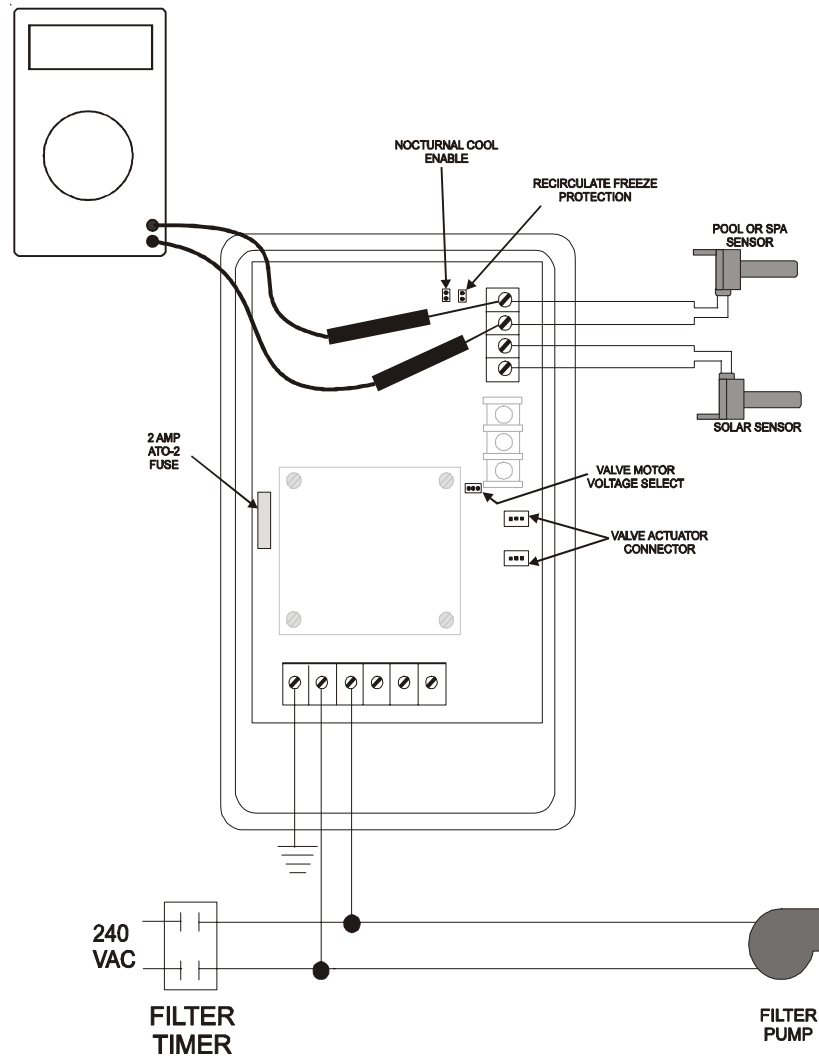

Measuring Voltage of Pool Sensor
 (Use the same method to measure the Solar Sensor)

Figure 5

Temperature/Resistance/Voltage

All Goldline controls use 10K thermistor sensors. When disconnected from the control the sensor will read 10K ohms at 25°C/77°F. Refer to the chart below for the resistance at other temperatures. For a given temperature, the resistance reading should be accurate to ±1%. For a given resistance reading, the temperature reading should be accurate to ±0.5°F. Voltage measurements should be accurate to ±2%. Ohm measurements made with sensor disconnected from unit. Voltage measurements made with sensor connected to unit and power applied. Sensor voltages are DC volts.

°F	Ohms	Volts	°F	Ohms	Volts	°F	Ohms	Volts	°F	Ohms	Volts
1	82,719	4.46	41	25,391	3.59	81	9,076	2.38	121	3,679	1.34
2	80,142	4.45	42	24,704	3.56	82	8,861	2.35	122	3,602	1.32
3	77,656	4.43	43	24,037	3.53	83	8,651	2.32	123	3,527	1.30
4	75,255	4.41	44	23,391	3.50	84	8,447	2.29	124	3,454	1.28
5	72,937	4.40	45	22,764	3.47	85	8,249	2.26	125	3,382	1.26
6	70,698	4.38	46	22,156	3.45	86	8,056	2.23	126	3,312	1.24
7	68,535	4.36	47	21,566	3.42	87	7,867	2.20	127	3,244	1.22
8	66,447	4.35	48	20,993	3.39	88	7,684	2.17	128	3,177	1.21
9	64,428	4.33	49	20,438	3.36	89	7,506	2.14	129	3,112	1.19
10	62,479	4.31	50	19,900	3.33	90	7,333	2.12	130	3,049	1.17
11	60,595	4.29	51	19,377	3.30	91	7,164	2.09	131	2,987	1.15
12	58,774	4.27	52	18,870	3.27	92	6,999	2.06	132	2,926	1.13
13	57,014	4.25	53	18,377	3.24	93	6,839	2.03	133	2,867	1.11
14	55,313	4.23	54	17,899	3.21	94	6,683	2.00	134	2,809	1.10
15	53,669	4.21	55	17,435	3.18	95	6,530	1.98	135	2,752	1.08
16	52,078	4.19	56	16,985	3.15	96	6,382	1.95	136	2,697	1.06
17	50,541	4.17	57	16,548	3.12	97	6,238	1.92	137	2,643	1.05
18	49,054	4.15	58	16,123	3.09	98	6,097	1.89	138	2,591	1.03
19	47,616	4.13	59	15,711	3.06	99	5,960	1.87	139	2,539	1.01
20	46,225	4.11	60	15,310	3.02	100	5,827	1.84	140	2,489	1.00
21	44,879	4.09	61	14,921	2.99	101	5,697	1.81	141	2,440	0.98
22	43,577	4.07	62	14,543	2.96	102	5,570	1.79	142	2,392	0.97
23	42,318	4.04	63	14,176	2.93	103	5,446	1.76	143	2,345	0.95
24	41,099	4.02	64	13,820	2.90	104	5,326	1.74	144	2,299	0.93
25	39,919	4.00	65	13,473	2.87	105	5,208	1.71	145	2,254	0.92
26	38,777	3.97	66	13,136	2.84	106	5,094	1.69	146	2,210	0.90
27	37,671	3.95	67	12,809	2.81	107	4,982	1.66	147	2,167	0.89
28	36,601	3.93	68	12,491	2.78	108	4,873	1.64	148	2,125	0.88
29	35,565	3.90	69	12,182	2.75	109	4,767	1.61	149	2,084	0.86
30	34,561	3.88	70	11,882	2.72	110	4,664	1.59	150	2,044	0.85
31	33,590	3.85	71	11,589	2.68	111	4,563	1.57	151	2,005	0.84
32	32,648	3.83	72	11,305	2.65	112	4,464	1.54	152	1,966	0.82
33	31,737	3.80	73	11,029	2.62	113	4,368	1.52	153	1,929	0.81
34	30,853	3.78	74	10,761	2.59	114	4,274	1.50	154	1,892	0.80
35	29,998	3.75	75	10,500	2.56	115	4,183	1.47	155	1,856	0.78
36	29,169	3.72	76	10,246	2.53	116	4,094	1.45	156	1,821	0.77
37	28,365	3.70	77	9,999	2.50	117	4,007	1.43	157	1,787	0.76
38	27,587	3.67	78	9,758	2.47	118	3,922	1.41	158	1,753	0.75
39	26,832	3.64	79	9,525	2.44	119	3,839	1.39	159	1,720	0.73
40	26,100	3.61	80	9,297	2.41	120	3,758	1.37	160	1,688	0.72

LIMITED WARRANTY Goldline warrants its Aqua Rite, Aqua Rite Pro, Aqua Trol, Aqua Logic and Pro Logic products (products with Goldline part numbers starting with AQ-RITE-, AQ-RT-PRO, AQ-TROL-, AQ-LOGIC-, AQL-P-, AQL-PS-, AQL-CL-, PL-P-, PL-PS-, and HPC-2) to be free from defects in material or workmanship, under normal use and service:

For **three years** from the date of the initial system installation on private, residential swimming pools within the USA or Canada and **one year** from the date of initial system installation on commercial installations, installations outside of the USA or Canada and for any replacement parts or accessory products, provided they are installed in accordance with the Goldline installation instructions and specifications provided with the product. If written proof of the date of the initial system installation is not provided to Goldline, the manufacturing datecode on the Aqua Rite, Aqua Rite Pro, Aqua Trol, Aqua Logic and Pro Logic electronics unit will be the sole determinant of the date of the initial system installation.

For residential installations in USA or Canada: If a product is defective in workmanship or materials and is removed and returned freight prepaid within three (3) years after the date of the initial system installation, Goldline will, at its option, either repair or replace the defective product and return it freight prepaid.

For commercial installations, installations outside the USA and Canada, and accessory products and replacement parts: If a product is defective in workmanship or materials and is removed and returned freight prepaid within one (1) year after the date of the initial system installation, Goldline will, at its option, either repair or replace the defective product and return it freight prepaid.

Contact any Goldline dealer or contact Goldline at 61 Whitecap Drive, North Kingstown, RI 02852 for warranty service. The costs incurred in removal and/or reinstallation of the product are NOT covered under this warranty. Some states do not allow limitations on how long an implied warranty lasts, so the above limitation may not apply to you.

WARRANTY EXCLUSIONS:

1. Material supplied or workmanship performed by others in process of installation.
2. Damage resulting from improper installation including installation on pools larger than the product rating.
3. Problems resulting from failure to operate the product(s) in accordance with the recommended instructions contained in product's owners manual(s).
4. Problems resulting from failure to maintain pool water chemistry in accordance with the recommendations in the owners manual(s).
5. Problems resulting from tampering, accident, abuse, negligence, unauthorized repairs or alternations, fire, flood, lightning, freezing, external water, degradation of natural stone used in or immediately adjacent to a pool or spa, war or acts of God.

DISCLAIMER. THE EXPRESS LIMITED WARRANTY ABOVE CONSTITUTES THE ENTIRE WARRANTY OF GOLDLINE WITH RESPECT TO ITS POOL AUTOMATION AND CHLORINATION PRODUCTS AND IS IN LIEU OF ALL OTHER WARRANTIES, EXPRESSED OR IMPLIED, INCLUDING WARRANTIES OF MERCHANTABILITY OR FITNESS FOR A PARTICULAR PURPOSE. THIS WARRANTY GIVES YOU SPECIFIC LEGAL RIGHTS, AND YOU MAY ALSO HAVE OTHER RIGHTS WHICH VARY FROM STATE TO STATE. IN NO EVENT SHALL GOLDLINE BE RESPONSIBLE FOR ANY CONSEQUENTIAL, SPECIAL OR INCIDENTAL DAMAGES OF ANY NATURE WHATSOEVER, INCLUDING, BUT NOT LIMITED TO, PERSONAL INJURY, PROPERTY DAMAGE, DAMAGE TO OR LOSS OF EQUIPMENT, LOST PROFITS OR REVENUE, COSTS OF RENTING REPLACEMENTS, AND OTHER ADDITIONAL EXPENSES, EVEN IF THE SELLER HAD BEEN ADVISED OF THE POSSIBILITY OF SUCH DAMAGES. SOME STATES DO NOT ALLOW THE EXCLUSION OF LIMITATION OF INCIDENTAL OR CONSEQUENTIAL DAMAGES, SO THE ABOVE LIMITATION OR EXCLUSION MAY NOT APPLY TO YOU.

NO WHOLESALE, AGENT, DEALER, CONTRACTOR OR OTHER PERSON IS AUTHORIZED TO GIVE ANY WARRANTY ON BEHALF OF GOLDLINE.

THIS WARRANTY IS VOID IF THE PRODUCT HAS BEEN ALTERED IN ANY WAY AFTER LEAVING THE FACTORY.